

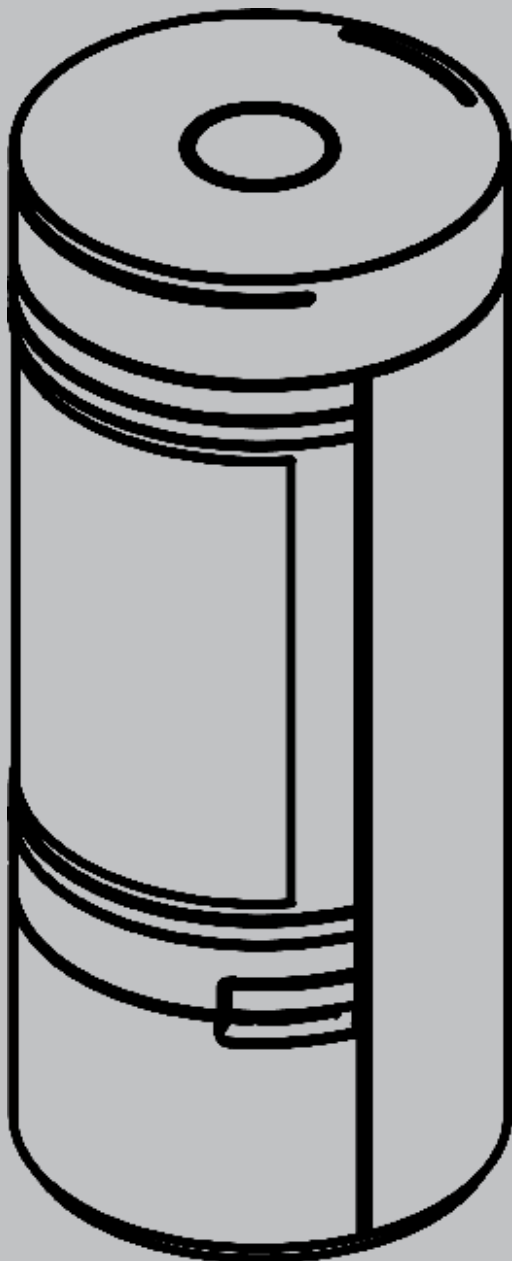

hunterstoves
GROUP

HALO



Radial Freestanding Wood Stove

JINDHR RevC
28/10/2024

WWW.HUNTERSTOVES.CO.UK



UK
CA CE

CONTENTS

INTRODUCTION

SAFETY

- 2.1 General 2
- 2.2 Safety Instructions 2

TECHNICAL SPECIFICATIONS

- 3.1 Technical Data 3
- 3.2 Test Data 3
- 3.3 Product Fiche 4
- 3.4 Item List 4
- 3.5 Appliance Dimensions 5
- 3.6 Combustible Material Clearances 6
- 3.7 Non-Combustible Material Clearances 6
- 3.8 Hearth Requirements 6

INSTALLATION REQUIREMENTS

- 4.1 Legal Requirements 7
- 4.2 Competent Person Scheme 7
- 4.3 Flue & Chimney Requirements 7
- 4.4 Hearth 7
- 4.5 Carbon Monoxide (CO) Alarm 7
- 4.6 Combustion Air Supply 8
- 4.7 Material Clearances 8
- 4.8 Certificate Of Compliance 8

STOVE ADJUSTMENT & OPERATION

- 5.1 Levelling the Appliance 9
- 5.2 Steel Baffle Removal 9
- 5.3 Catalyst Servicing Notes & Removal 9-10
- 5.4 Grate & Ashpan Fitting 10
- 5.5 Fire Bricks 11-12
- 5.6 Direct Air 13
- 5.7 Air Control & DEFRA Setting 14
- 5.8 Flue Connection 15
- 5.9 Lighting the Appliance 16
- 5.10 Running the Appliance 17

INSTALLATION & SERVICING

- 6.1 Overview of a Typical Top Flue Installation 18
- 6.2 Commissioning 18
- 6.3 Servicing Checklist 19
- 6.4 Servicing Notes 19-20
- 6.5 General Notes 21
- 6.6 Glass Replacement 21
- 6.7 Rope seal Replacement 22
- 6.8 Handle Adjustment 22

TROUBLESHOOTING

WARRANTY

SERVICE RECORDS

- 22
- 23-24
- 25

INTRODUCTION

Welcome to the Hunter Stoves family.

Thank you for purchasing a HALO Radial Freestanding Wood Stove.

This stove was designed and built to be a high-performance heating appliance, and we hope it will bring you great enjoyment. The natural environment is important to us, as such our stoves are manufactured to provide you with a clean and efficient burn that will keep you warm through cold winter nights. This appliance was designed and manufactured to the highest quality, performance and safety requirements and is supplied with an installation and user manual (this document) and should be kept safe for future reference. Installation and maintenance of the appliance should be carried out by a qualified professional. The professional is responsible for the installation of this appliance and the information in this manual will ensure it is installed safely and correctly. If the information is not clear, national or local regulations must be observed. Hunter Stoves will not accept responsibility for any fault arising from incorrect installation or operation of this product.

SAFETY

2.1 General

Please read all instructions carefully before attempting to install or operate the appliance.

2.2 Safety Instructions

Special care must be taken when installing the stove and the requirements of the Health and Safety at Work Act 1974 must be adhered to.

Handling

This appliance is very heavy. Adequate facilities must be available for loading, unloading and side handling.

Fire Cement

Some types of fire cement are caustic and should not be allowed to come into contact with the skin. In case of contact, wash immediately with plenty of water.

Asbestos

This stove contains no asbestos. If there is any possibility of disturbing any asbestos in the course of installation, then please seek specialist guidance and use the appropriate protective equipment.

Metal Parts.

When installing or servicing this stove, care should be taken to avoid the possibility of personal injury.

Stove Body Paint

The stove paint curing process takes place at room temperature and the surface coating is virtually free from fumes and odours. When being put into operation for the first time we would recommend that windows and doors are opened for a short period to provide ventilation.



WARNING!

The appliance is a heating device and all visible surfaces become extremely hot during operation. Avoid contact with the appliance to prevent burns. It is recommended that a fire-guard is installed in the presence of children, the elderly or the infirm. The fire-guard should be manufactured in accordance with BS8423.

TECHNICAL SPECIFICATIONS

3.1 Technical Data

Technical Information for Solid Fuel Local Space Heaters according to Regulation (EU) 2015/1185

Product Range:	HALO
Indirect Heating Functionality:	No
Preferred Fuel	Wood logs with moisture content < 20%



Stove Model	HALO Radial
Nominal Heat Output	4.9kW
Efficiency	84%
Min. Draft	12Pa
Average CO ₂	10.4%
CO (@13% O ₂)	737mg/Nm ³
OGC (@13% O ₂)	102mg/Nm ³
NOx (@13% O ₂)	89mg/Nm ³
PM (@13% O ₂)	10mg/Nm ³
Mean Flue Temperature	224°C
Flue Gas Mass Flow Rate	4.2g/s
Weight	125kg

3.2 Test Data

Model	Test Report Reference	Nominal Heat Output, P _{nom} [x.x] kW	Useful Efficiency, η _{th, nom} [x] %	Seasonal Efficiency, η _s [x] %	Space heating emissions at nominal heat output			
					PM	OGC	CO	NO _x
					[x] mg/Nm ³ (at 13 % O ₂)			
HALO Radial Freestanding Stove	300-ELAB-2658-EN-rev1	4.9	84	74	10	102	737	89

Results are in accordance with EN 13240:2001 + A2:2004 section A.4.7, and EN 16510-1:2018 section A.4.7. Emission of NOx and OGC was determined in accordance with DS/CEN/TS 15883:2009. Emission of PM was determined in accordance with EN 16510-1:2018.

3.3 Product Fiche

Stove Model	HALO Radial
Energy Efficiency Class	A+
Direct Heat Output (kW)	4.9
Indirect Heat Output (kW)	N/A
Energy Efficiency Index (EEI)	112
Useful Energy Efficiency at Nominal Heat Output (%)	84%
Safety Precautions	Local space heater must be assembled, installed and maintained in accordance with manufacturers instructions.

In accordance with Regulations (EU) 2015/1186

Characteristics when operating with preferred fuel only:

Item	Symbol	Value	Unit
Auxiliary Electricity Consumption			
At nominal heat output	$e_{l_{max}}$	N/A	kW
At minimum heat output	$e_{l_{min}}$	N/A	kW
In standby mode	$e_{l_{SB}}$	N/A	kW
Permanent Pilot Flame Power Requirement			
Pilot flame power requirement (if applicable)	P_{pilot}	N/A	kW
Type of heat output/room temperature control:	Single stage heat output, no room temperature control		
Other control option(s):	N/A		

Manufacturer Details:

Name: Hunter Stoves Ltd.
 Address: Trevilla Park, Slaughterbridge, Camelford, Cornwall, England, PL32 9TT
 Email: info@hunterstoves.co.uk
 Website: www.hunterstoves.co.uk

3.4 Item List

Note the items listed when removing the packaging. Check the appliance and accessories for any damages. Please contact the retailer if any of the components are missing or damaged. The appliance is delivered in packaging that can be recycled. The glass cannot be recycled so must be disposed of, along with any ceramics or porcelain waste, in accordance with local regulations. Keep plastic bags away from children.

Unpacking and Removing Internal Components

Remove the transport brackets, securing screws and box, as well as all external panels and loose internal components.

This will make handling the stove easier; allow access to fixings and the flue outlet; as well as protect the components from damage during the installation process.

1. Box
2. HALO Radial
3. Instructions and Documentation
4. Gauntlet (pair)

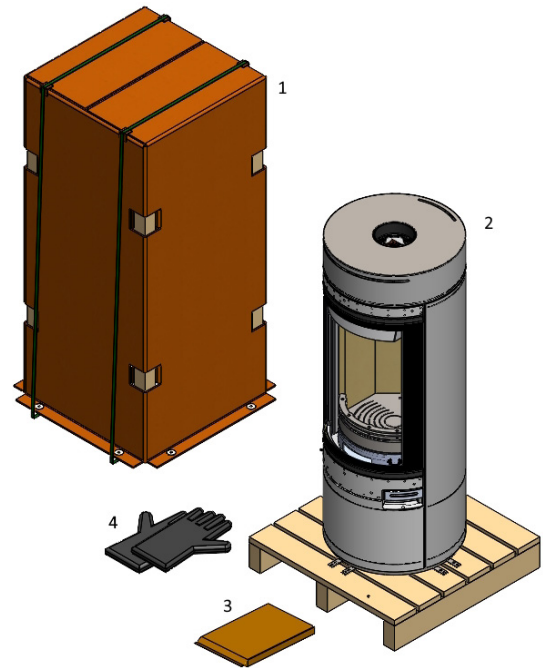

3.5 Appliance Dimensions

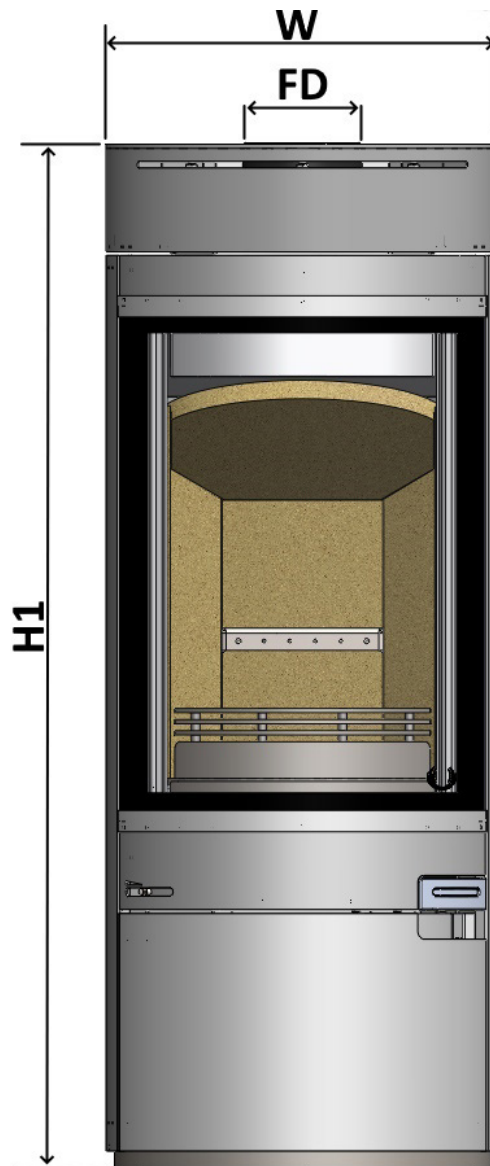

DIMENSIONS	H1	W	FD
HALO Radial	1205mm	463mm	127mm

3.6 Combustible Material Clearances

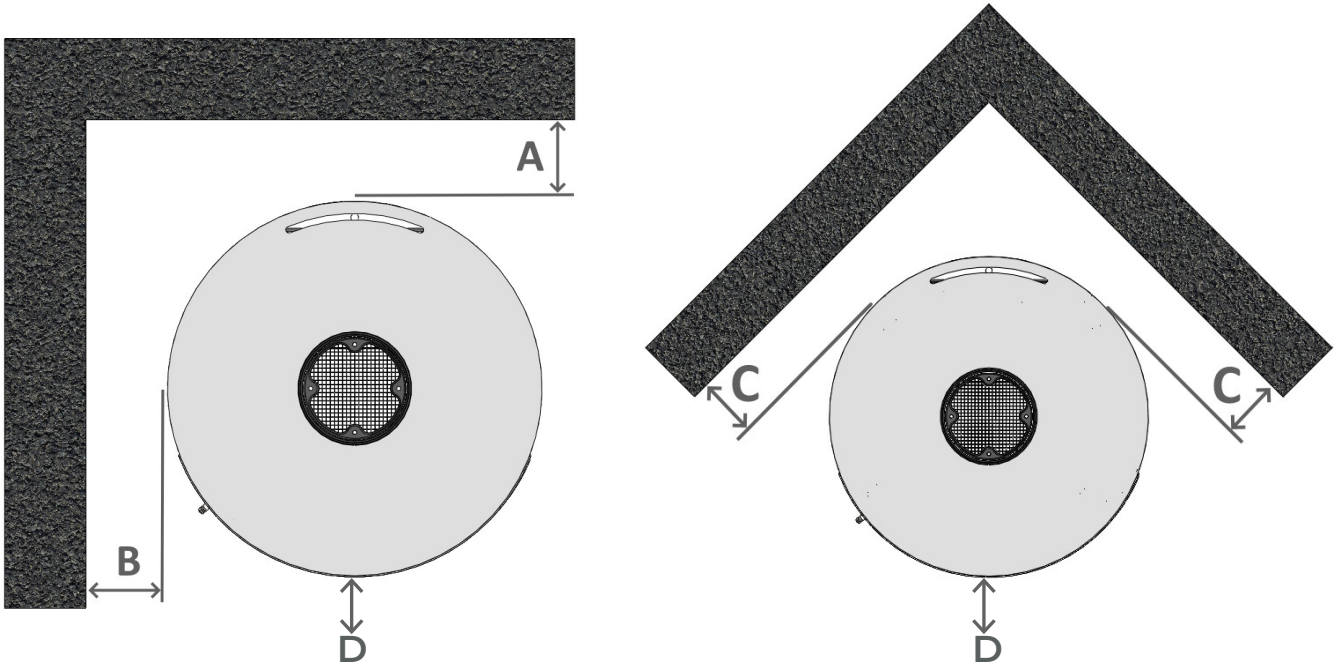

Model	A (to Twin-Walled Flue)	B Combustible	C Combustible	D Front to Furniture
HALO Radial	50mm	500mm	150mm	950mm

3.7 Non-Combustible Material Clearances

Clearances to non-combustible surfaces can be as close as 50mm.

However, for optimum performance and heat output, we recommend a clearance of 150mm

3.8 Hearth Requirements

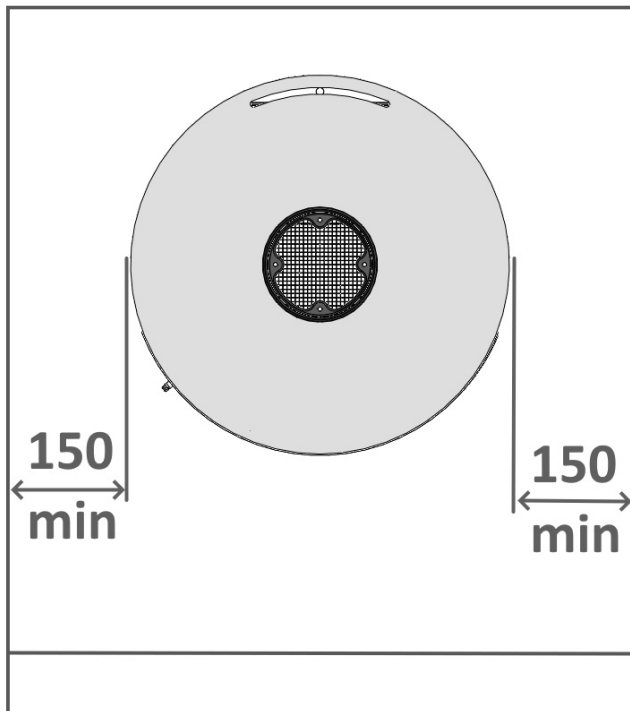

The position of the stove and the size of the hearth are governed by building regulations (Approved Document J). If in doubt as to the positioning of the stove, expert advice should be sought either from the supplier, installer or the local building inspector.

INSTALLATION REQUIREMENTS

4.1 Legal Requirements

These instructions cover the requirements to ensure satisfactory installation of the appliance, although details may need slight modification to suit particular local site conditions. In all cases the installation must comply with current building regulations, local authority byelaws, European and national standards and other specifications or regulations.

4.2 Competent Person Scheme

Hunter Stoves Group recommend that this stove be installed by a member of an accredited competent person scheme e.g. HETAS. If the installer is not a member of a competent person scheme, it is a legal requirement in the UK, to notify your local Building Control Officer in advance of any installation work starting.

4.3 Flue & Chimney Requirements

The appliance installation and connection to a flue or chimney must comply with current building regulations. Ensure the flue or chimney is inspected and swept prior to installation by a qualified chimney sweep.

It is essential that all connections between the appliance and flue or chimney are sealed and made airtight. Any bend in the chimney or connected flue pipe should not exceed 45°.

If the installation requires a register plate or flexible flue liner system to be fitted, it must conform to the current building regulations.

Suitable access to the full length of the flue or chimney system must be provided for cleaning and the removal of debris.



WARNING!

This appliance must not be installed into a flue or chimney that serves any other heating appliance.

4.4 Hearth

The Stove can stand on either a solid, non-cumbustible hearth at least 125mm thick, or a 12mm superimposed hearth, ensuring the floor is of adequate load bearing capacity. Please refer to Building Regulation Approved Document J for further information

The appliance must be installed on a floor with adequate load-bearing capacity. If the existing construction does not meet this requirement, suitable measures (e.g. load distributing plate) should be put in place.

4.5 Carbon Monoxide (CO) Alarm

In compliance with building regulations, a carbon monoxide (CO) alarm must be installed in the room where the stove is located that conforms to BS EN 50291. See EN 50292 and the alarm manufacturer's instructions for installation guidance.



The use of such an alarm is not considered a substitute for regular maintenance or servicing of the appliance and flue system.

4.6 Combustion Air Supply

The room (or space) in which the appliance will be installed does not require a permanently open air vent as standard.

Due consideration should be given to air requirements for any other appliance in the same room or space.

Any air opening must be kept clear from blockage or obstruction.

Attention is needed in new-build properties where the design air permeability is less than $5\text{m}^3/(\text{h}\cdot\text{m}^2)$ at 50 Pa. Approved Document J - Appendix F gives further information. A window opening is not appropriate.

Fitting a stove in a room which also contains an extractor fan and/or cooker hood should be avoided where possible. If this is unavoidable, the suitability of the space for fitting this appliance must be decided at the discretion of a qualified installer, and a flue draught interference test must be performed.

4.7 Material Clearances

Clearances to combustible materials are stated in accordance with BS EN 13240, where a combustible surface at the stated distance will be less than 65°C above ambient room temperature (under test conditions). This applies in all directions, e.g. towards walls and towards the hearth.

For clearance to non-combustible materials Hunter Stoves recommends a minimum gap of 150 mm around the stove to provide space for convection around the appliance, improving heat transfer to the room.

For additional information, refer to pages 6/7. Additionally more information can be found in Building Regulations Approved Document J.

4.8 Certificate of Compliance (UK)

After completion of the appliance installation please ensure the form, to the right (specimen) is completed by the installation engineer to comply with the requirements of HETAS and building regulations.

The installation engineer must supply these details, including registration number for any insurance details that may need changing after installation of the appliance.

HETAS LTD - CERTIFICATE OF COMPLIANCE
PLEASE TICK APPROPRIATE BOXES OR ENTER DETAILS IN BOXES BELOW

Customer Name: _____
Installation Address: _____
Installation Address: _____
Installation Address: _____
Type: _____
Postcode: _____
Local Authority Name: _____
Building Company Name: _____
Building Engineer's Name: _____

DESCRIPTION OF WORK

Location: Garage Dining Room Kitchen Utility Room Bedroom Other: _____

Appliance: Dry Open Fire Open Fire with Radiator Dry Stove Central Heating Boiler Dry Room Heater Radiant Panel Floor Warmer Independent Boiler Radiant Panel Floor Warmer Radiant Panel Floor Warmer Radiant Panel Floor Warmer Radiant Panel Floor Warmer

System: New Heating and Hot Water System Upgrade Existing Heating and Hot Water System Dry System Only

Flue System: In-Header/Under System Installed?

Chimney: New Insulated Factory Made Chimney System Installed

Relining of existing chimney: Turn Back Flue/Liner to the Class 1 Appliance Cast Irons Liner

Right to Disconnect: No Right to Disconnect User Details: _____

Hearth: New Hearth Constructed Existing Hearth Covered Up/Rebuilt

Additional Information: _____

Connected to Gas: Yes No Socket takes power and/or gas

Provision for emergency shut-off function: Yes No Chimney Gas Valve Location: _____

Air supply: Has a permanently open air vent been fitted? Yes No

Is a permanent open air vent provided at the location of the appliance? Yes No If yes, please provide details of the vent: _____

Chimney or approved Carbon Monoxide alarm has been fitted

Setting & Commissioning in Accordance with Appendix B

Declaration of completion: As the competent person responsible for the work described above, I confirm that the appliance and associated work has been installed in accordance with the HETAS rules of registration, and that the work complies with Regulations 1 and 2 of the Building Regulations, and Approved Documents A, B, C, D, E, F, G, H, J, K, L, M, N, O, P, Q, R, S, T, U, V, W, X, Y, Z, AA, AB, AC, AD, AE, AF, AG, AH, AI, AJ, AK, AL, AM, AN, AO, AP, AQ, AR, AS, AT, AU, AV, AW, AX, AY, AZ, BA, BB, BC, BD, BE, BF, BG, BH, BI, BJ, BK, BL, BM, BN, BO, BP, BQ, BR, BS, BT, BU, BV, BW, BX, BY, BZ, CA, CB, CC, CD, CE, CF, CG, CH, CI, CJ, CK, CL, CM, CN, CO, CP, CQ, CR, CS, CT, CU, CV, CW, CX, CY, CZ, DA, DB, DC, DD, DE, DF, DG, DH, DI, DJ, DK, DL, DM, DN, DO, DP, DQ, DR, DS, DT, DU, DV, DW, DX, DY, DZ, EA, EB, EC, ED, EE, EF, EG, EH, EI, EJ, EK, EL, EM, EN, EO, EP, EQ, ER, ES, ET, EU, EV, EW, EX, EY, EZ, FA, FB, FC, FD, FE, FF, FG, FH, FI, FJ, FK, FL, FM, FN, FO, FP, FQ, FR, FS, FT, FU, FV, FW, FX, FY, FZ, GA, GB, GC, GD, GE, GF, GG, GH, GI, GJ, GK, GL, GM, GN, GO, GP, GQ, GR, GS, GT, GU, GV, GW, GX, GY, GZ, HA, HB, HC, HD, HE, HF, HG, HH, HI, HJ, HK, HL, HM, HN, HO, HP, HQ, HR, HS, HT, HU, HV, HW, HX, HY, HZ, IA, IB, IC, ID, IE, IF, IG, IH, II, IJ, IK, IL, IM, IN, IO, IP, IQ, IR, IS, IT, IU, IV, IW, IX, IY, IZ, JA, JB, JC, JD, JE, JF, JG, JH, JI, JJ, JK, JL, JM, JN, JO, JP, JQ, JR, JS, JT, JU, JV, JW, JX, JY, JZ, KA, KB, KC, KD, KE, KF, KG, KH, KI, KJ, KK, KL, KM, KN, KO, KP, KQ, KR, KS, KT, KU, KV, KW, KX, KY, KZ, LA, LB, LC, LD, LE, LF, LG, LH, LI, LJ, LK, LL, LM, LN, LO, LP, LQ, LR, LS, LT, LU, LV, LW, LX, LY, LZ, MA, MB, MC, MD, ME, MF, MG, MH, MI, MJ, MK, ML, MM, MN, MO, MP, MQ, MR, MS, MT, MU, MV, MW, MX, MY, MZ, NA, NB, NC, ND, NE, NF, NG, NH, NI, NJ, NK, NL, NM, NN, NO, NP, NQ, NR, NS, NT, NU, NV, NW, NX, NY, NZ, OA, OB, OC, OD, OE, OF, OG, OH, OI, OJ, OK, OL, OM, ON, OO, OP, OQ, OR, OS, OT, OU, OV, OW, OX, OY, OZ, PA, PB, PC, PD, PE, PF, PG, PH, PI, PJ, PK, PL, PM, PN, PO, PP, PQ, PR, PS, PT, PU, PV, PW, PX, PY, PZ, QA, QB, QC, QD, QE, QF, QG, QH, QI, QJ, QK, QL, QM, QN, QO, QP, QQ, QR, QS, QT, QU, QV, QW, QX, QY, QZ, RA, RB, RC, RD, RE, RF, RG, RH, RI, RJ, RK, RL, RM, RN, RO, RP, RQ, RR, RS, RT, RU, RV, RW, RX, RY, RZ, SA, SB, SC, SD, SE, SF, SG, SH, SI, SJ, SK, SL, SM, SN, SO, SP, SQ, SR, SS, ST, SU, SV, SW, SX, SY, SZ, TA, TB, TC, TD, TE, TF, TG, TH, TI, TJ, TK, TL, TM, TN, TO, TP, TQ, TR, TS, TT, TU, TV, TW, TX, TY, TZ, UA, UB, UC, UD, UE, UF, UG, UH, UI, UJ, UK, UL, UM, UN, UO, UP, UQ, UR, US, UT, UU, UV, UW, UX, UY, UZ, VA, VB, VC, VD, VE, VF, VG, VH, VI, VJ, VK, VL, VM, VN, VO, VP, VQ, VR, VS, VT, VU, VV, VW, VX, VY, VZ, WA, WB, WC, WD, WE, WF, WG, WH, WI, WJ, WK, WL, WM, WN, WO, WP, WQ, WR, WS, WT, WU, WV, WW, WX, WY, WZ, XA, XB, XC, XD, XE, XF, XG, XH, XI, XJ, XK, XL, XM, XN, XO, XP, XQ, XR, XS, XT, XU, XV, XW, XX, XY, XZ, YA, YB, YC, YD, YE, YF, YG, YH, YI, YJ, YK, YL, YM, YN, YO, YP, YQ, YR, YS, YT, YU, YV, YW, YX, YY, YZ, ZA, ZB, ZC, ZD, ZE, ZF, ZG, ZH, ZI, ZJ, ZK, ZL, ZM, ZN, ZO, ZP, ZQ, ZR, ZS, ZT, ZU, ZV, ZW, ZX, ZY, ZZ

Signature: _____ Print name: _____ Date: _____

THIS CERTIFICATE IS VALID FOR 12 MONTHS FROM THE DATE OF ISSUANCE AND IS NOT VALID FOR REUSE.

WHO MAY BE REQUIRED TO PROVIDE IT IN ANY FUTURE SALE OF THE PROPERTY:

HETAS Ltd PO Box 87, Stages House, Elm 16-17 St

HETAS Ltd 0 (for 016)

STOVE ADJUSTMENT & OPERATION

5.1 Levelling the Appliance

(Outer panels removed for clarity.)

Lift lower front panel and remove for access to adjusting screws.

Position the appliance on the hearth and adjust the 4 leveling feet until the top plate is level.

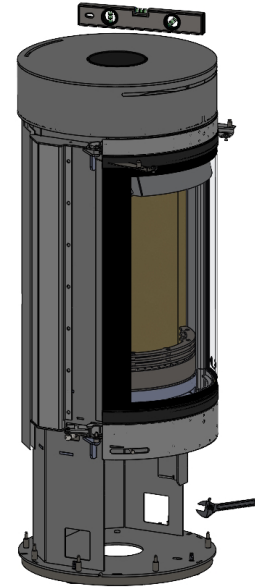

5.2 Steel Baffle Removal

(Top air deflector removed for clarity.)

Remove the M6 nuts & washers. This will allow the steel baffle to drop down.

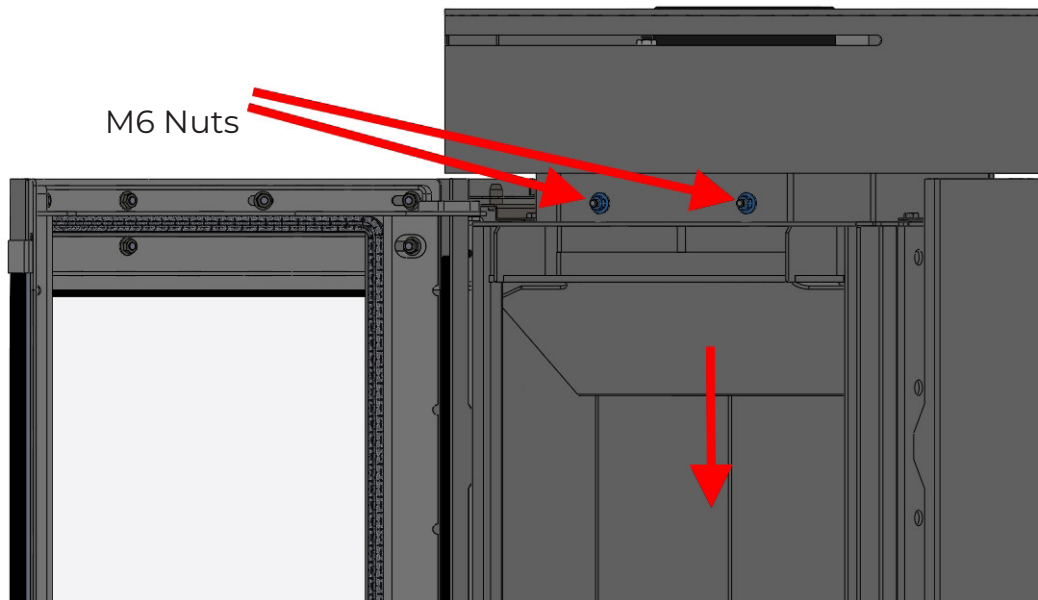

5.3 Catalyst Servicing Notes

The catalyst is self-cleaning in normal operational mode. However, in some situations such as burning poorly seasoned or smoky wood, if there is a poor chimney draught or the fire is burnt in a slow mode for long periods, then soot may accumulate on the surfaces of the catalytic converter. The fire should be burnt at a high heat on a regular basis to help burn off any soot that may start to accumulate.

To clean the catalyst, first remove the Steel Baffle and Retaining Ring from the stove then simply dust off any soot with a dry paint brush, gently blow through it with an air line or pump, being careful not to inhale any dust, or gently vacuum over the faces, being careful not to brush or touch the face with hard objects which could damage the delicate foil substrate.

A correctly functioning catalyst will show a light covering in dry grey ash, which is easily removed as above. If it is heavily coated in black soot, with evidence of cells blocking, then the catalyst should be brushed off, and then washed in cold water, do not use any detergents which will damage the coating.

5.3 Catalyst Removal

(View from the underside.)

Rotate the Catalyst Retaining Ring clockwise until the slots align with the retaining hooks. Allow the Retaining Ring to drop down, this will allow the Catalyst to also drop down.

Reverse the procedure for re-fitting.

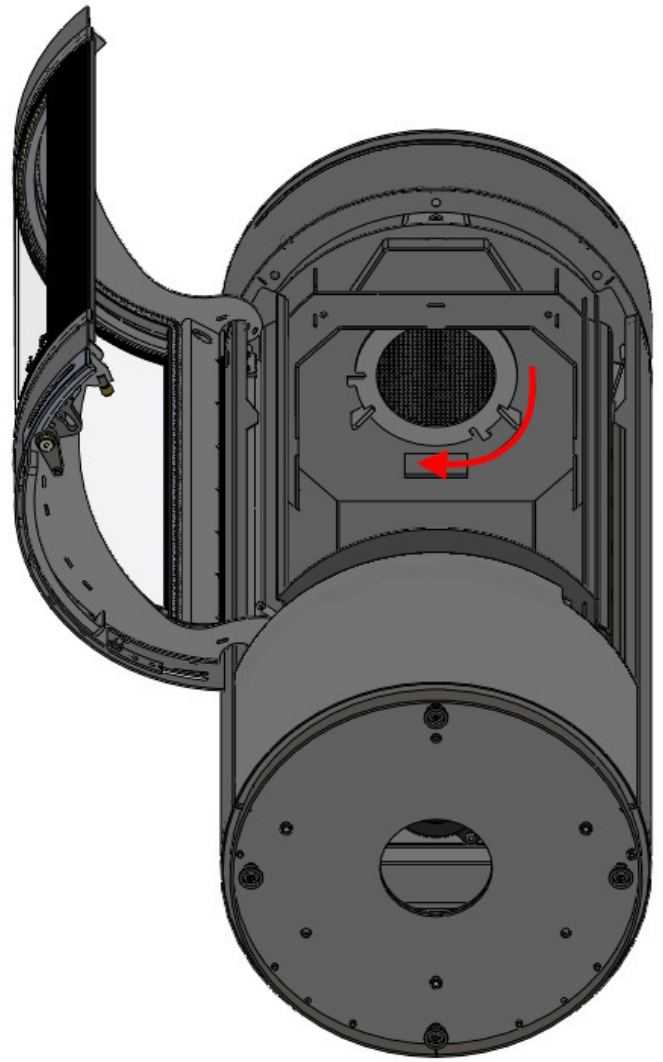

5.4 Grate & Ashpan Fitting

Rotate Grate to enter through door opening, twist horizontal and lower onto the support brackets inside the appliance. Slide Ashpan into position.

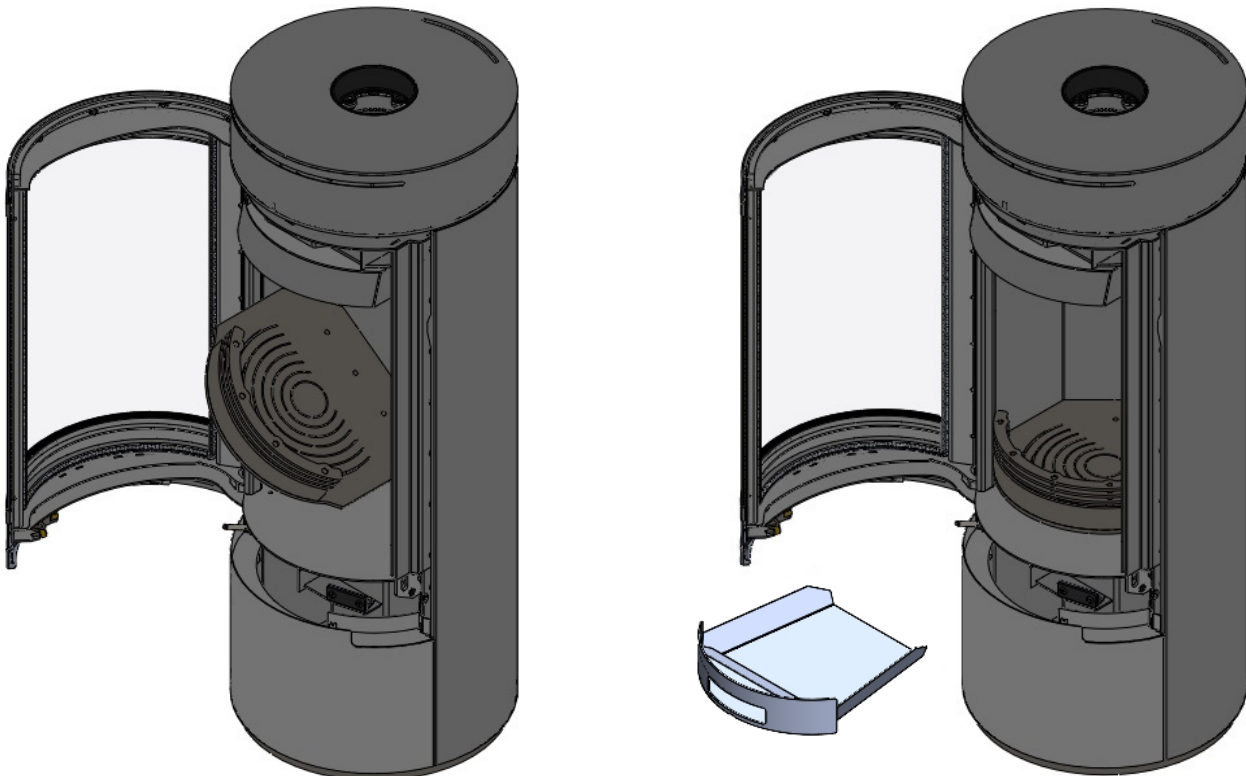

5.5 Fire Brick Fitting

Complete Firebox assembly in isolation



1. Slide lower rear brick into place, so that it sits under the Turbo Bar.

2. Fit upper rear brick into the Turbo Bar.

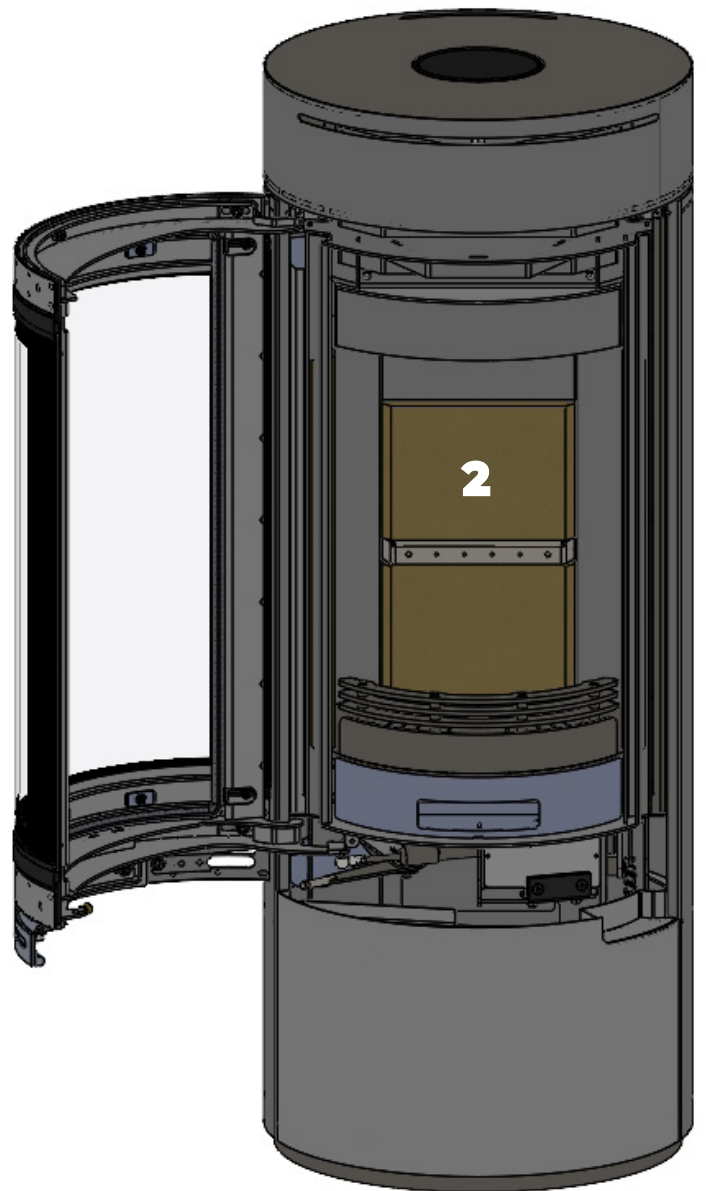
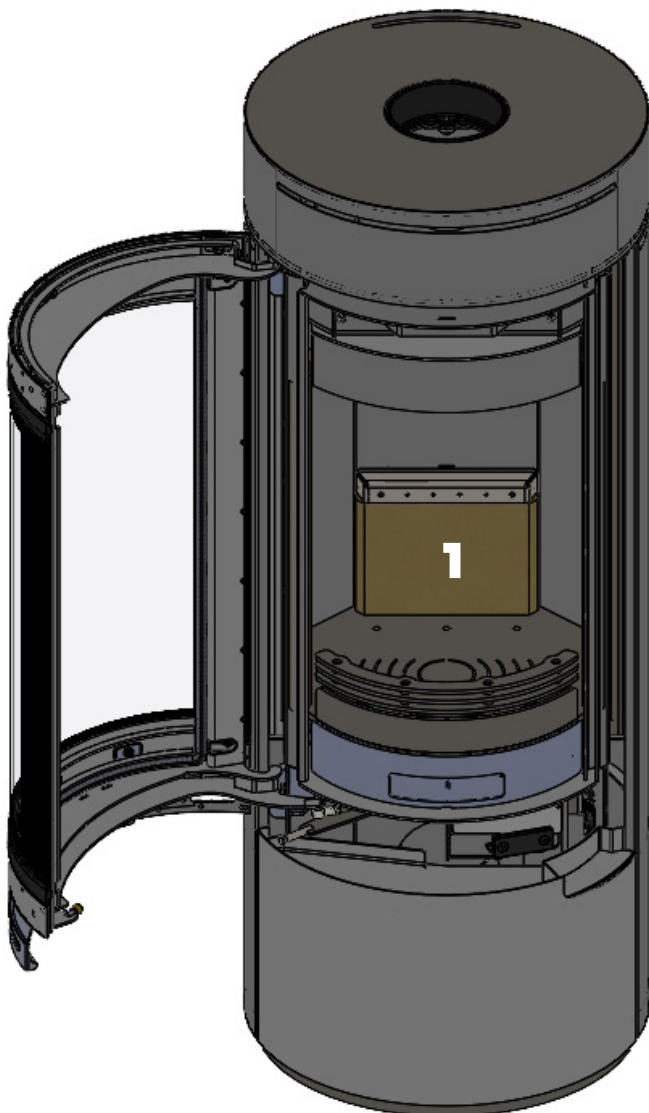

3. Fit corner bricks adjacent to rear bricks

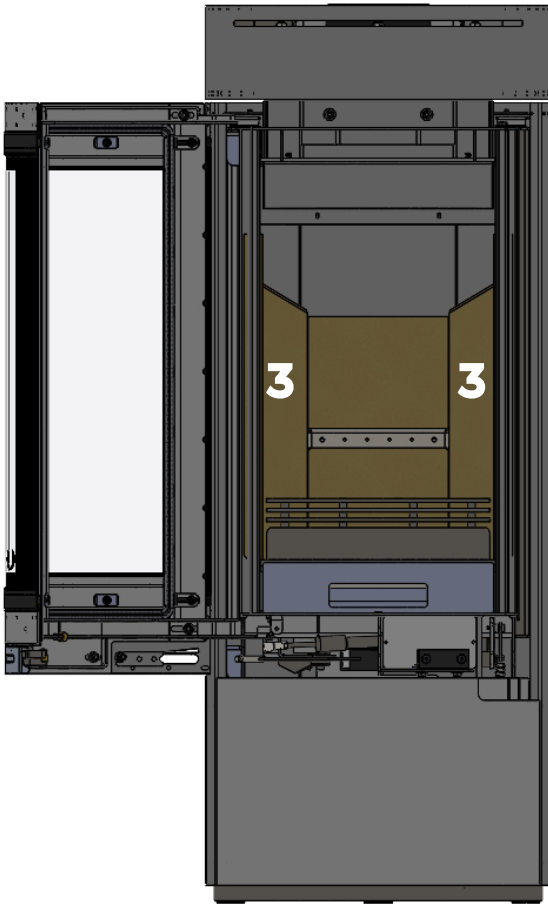

4. Lift Baffle brick into place and hold above rear & corner bricks

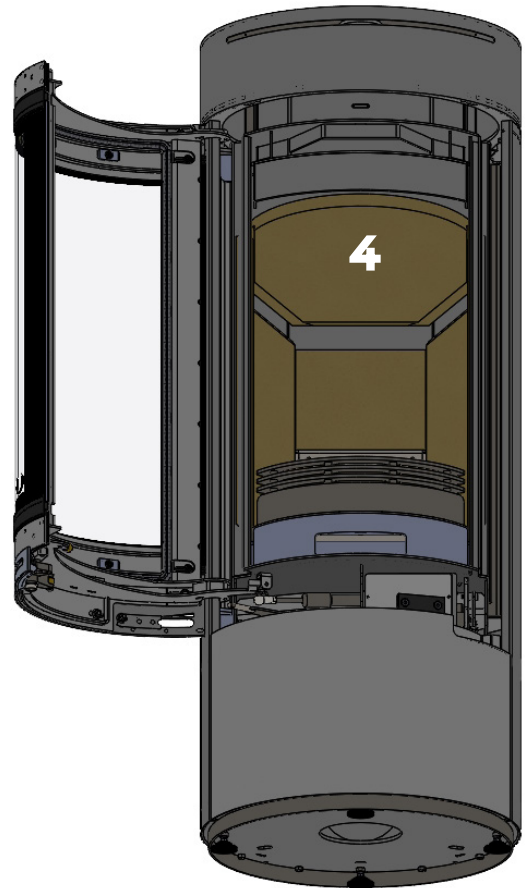

5. Fit side bricks and lower the baffle brick down (4) to hold the other bricks in place.

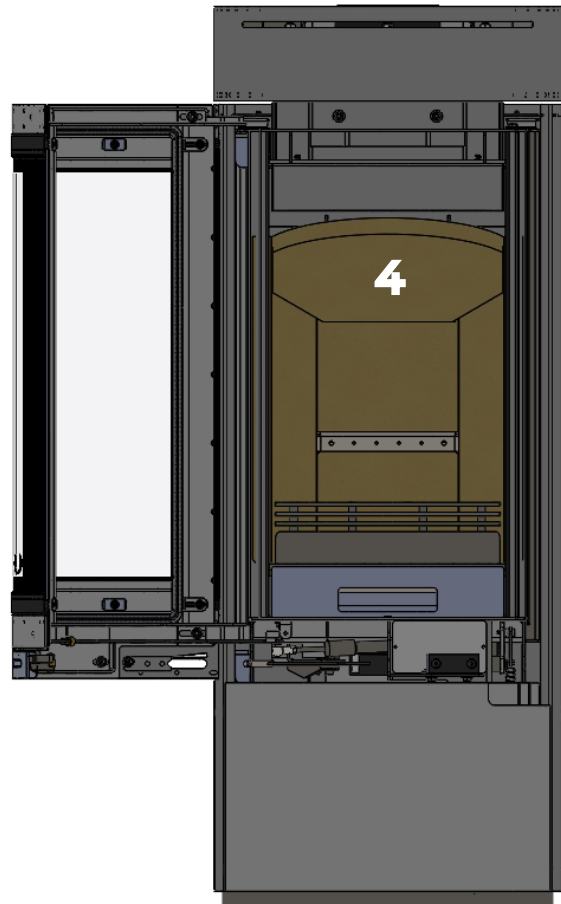
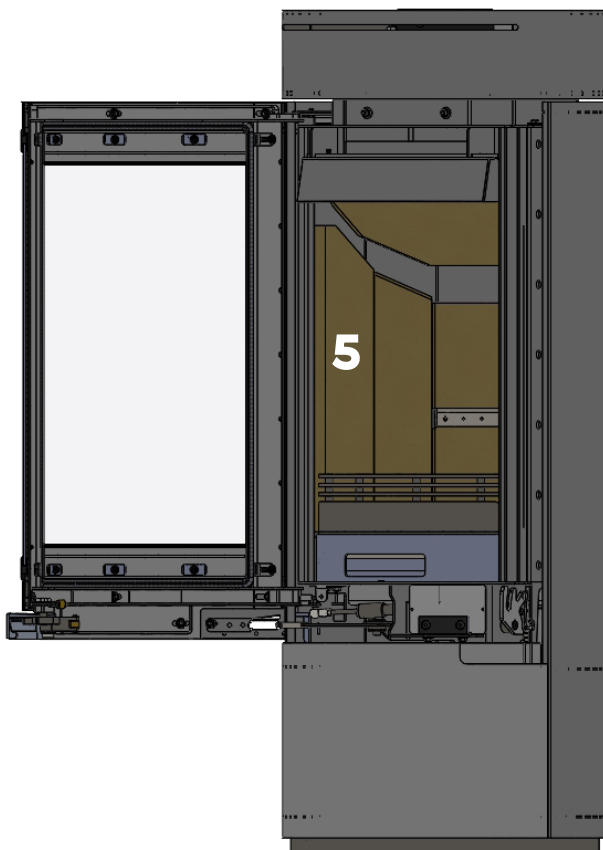

5.6 Direct Air (optional)

For optimal efficiency it is recommended that the optional direct air attachment is fitted.

The direct air connection has an outer diameter of 100mm.

Option 1 - through the base plate.

(If the proposed installation is prepared with a
Ø100mm underfloor air inlet pipe.)

(Appliance sectioned for clarity)

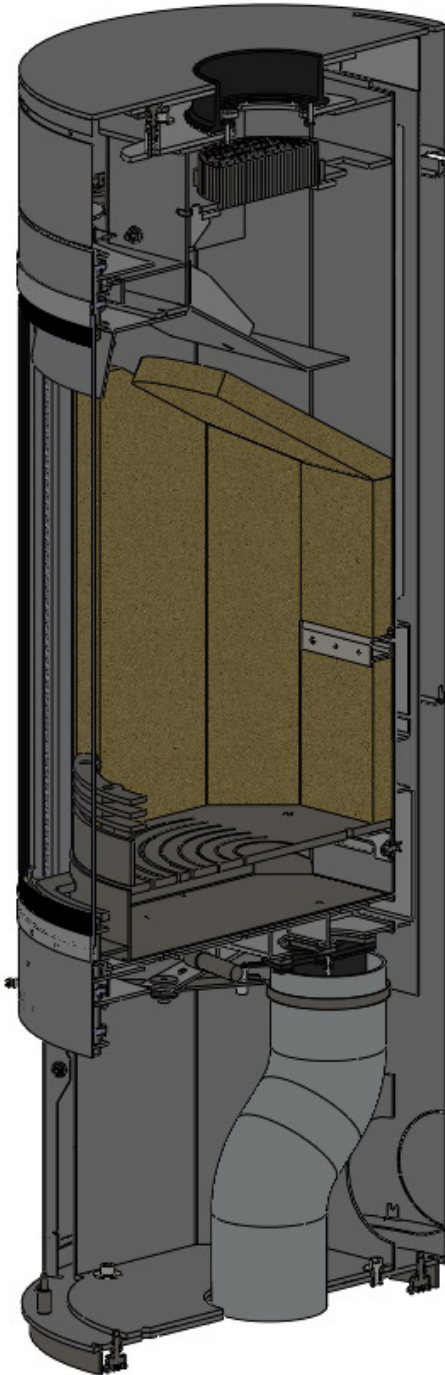

Option 2 - through the back panel

(The conventional installation)

(Appliance sectioned for clarity)

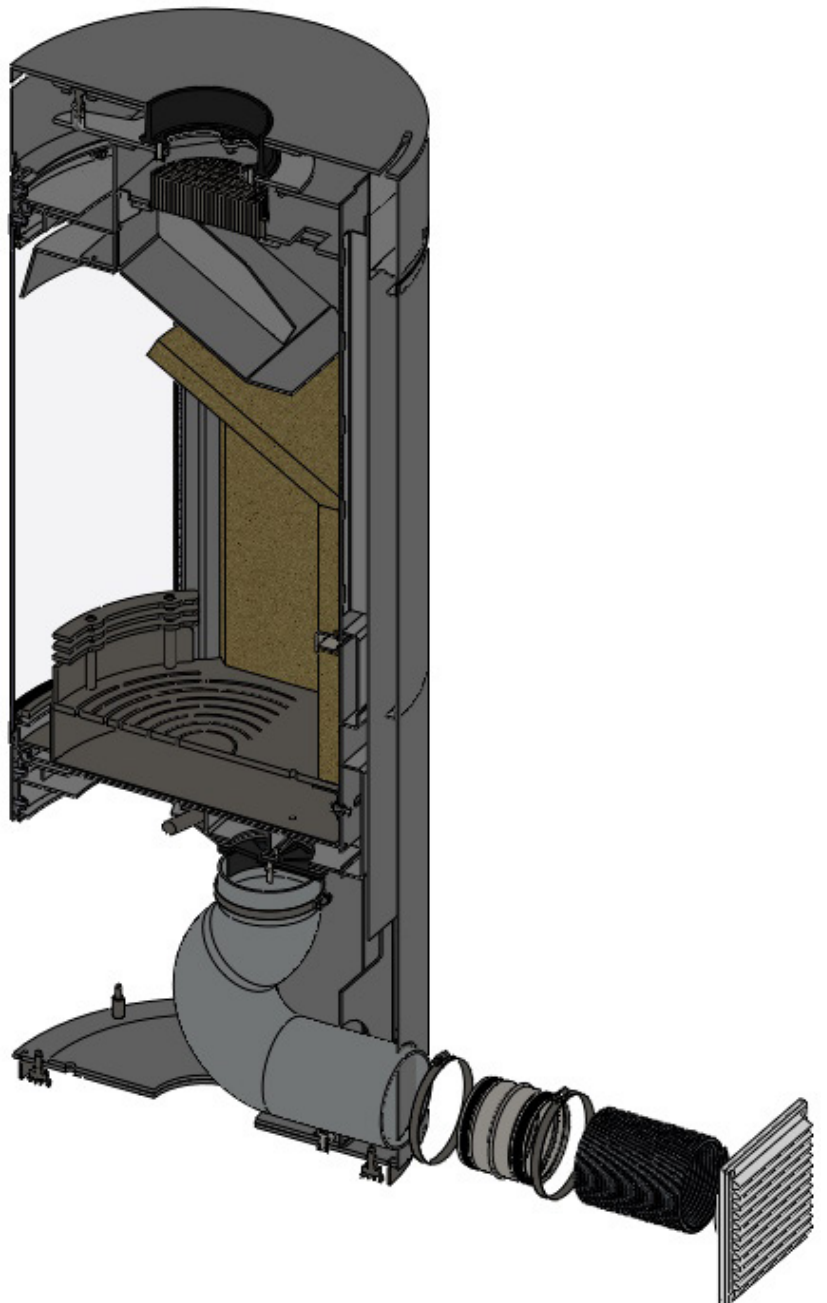

5.7 Air Control & DEFRA Setting

This appliance has a single air control in the bottom left corner of the Door.

Open left - Close right.

This appliance is also supplied with a DEFRA compliant smoke control setting infill.

If the appliance is installed in a smoke controlled area the infill must be in place.

If the appliance is installed outside a smoke control area the infill can be removed to give more control over the lower burn rates.

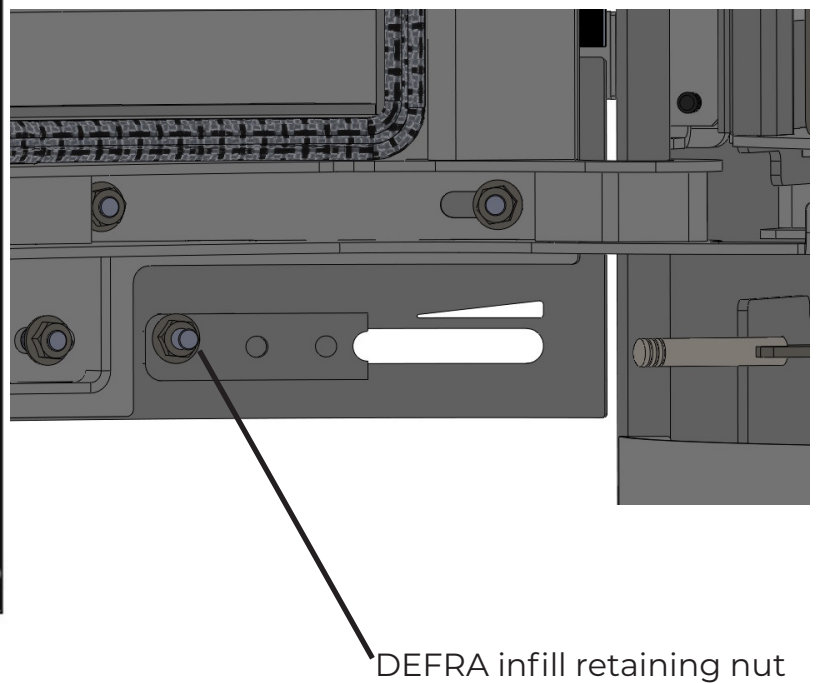
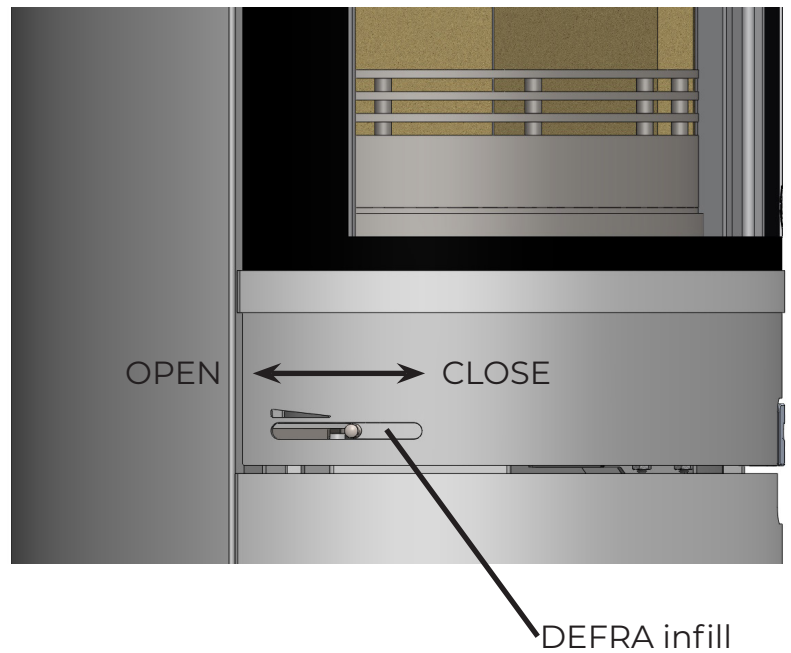

5.8 Flue Connection

- Before applying fire cement, ensure gloves are worn.
- Apply the fire cement inside the flue collar.
- Ensure it is evenly distributed.



- Press the flue pipe firmly into the flue collar.
- Continue with the rest of the flue installation according to the local standards and regulations.

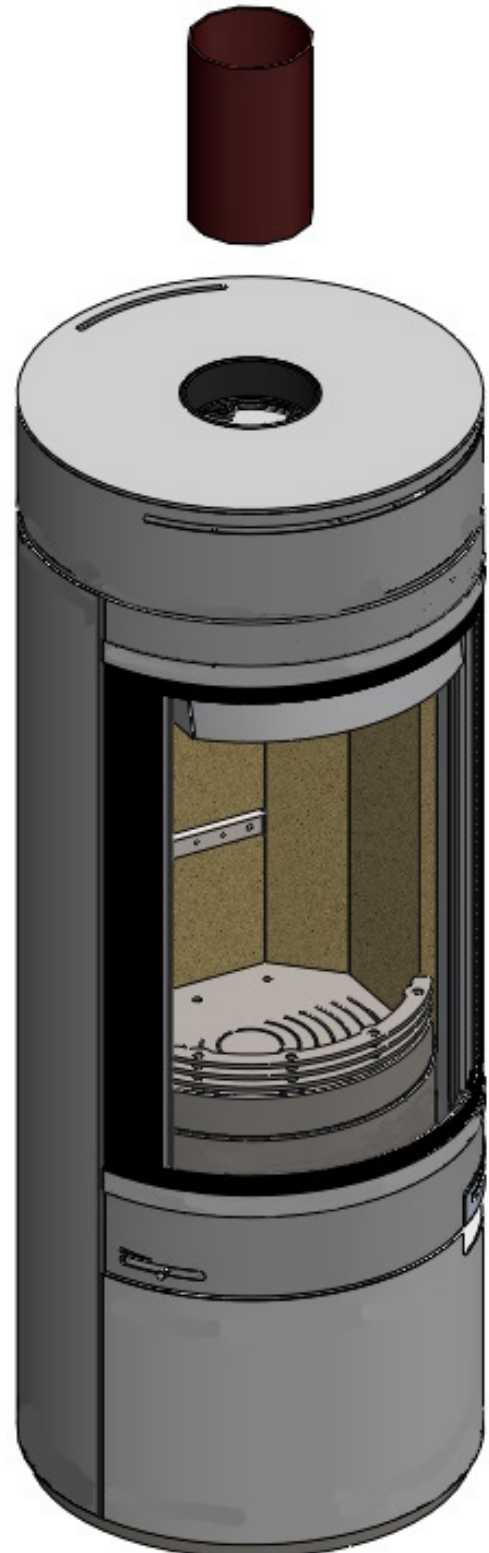
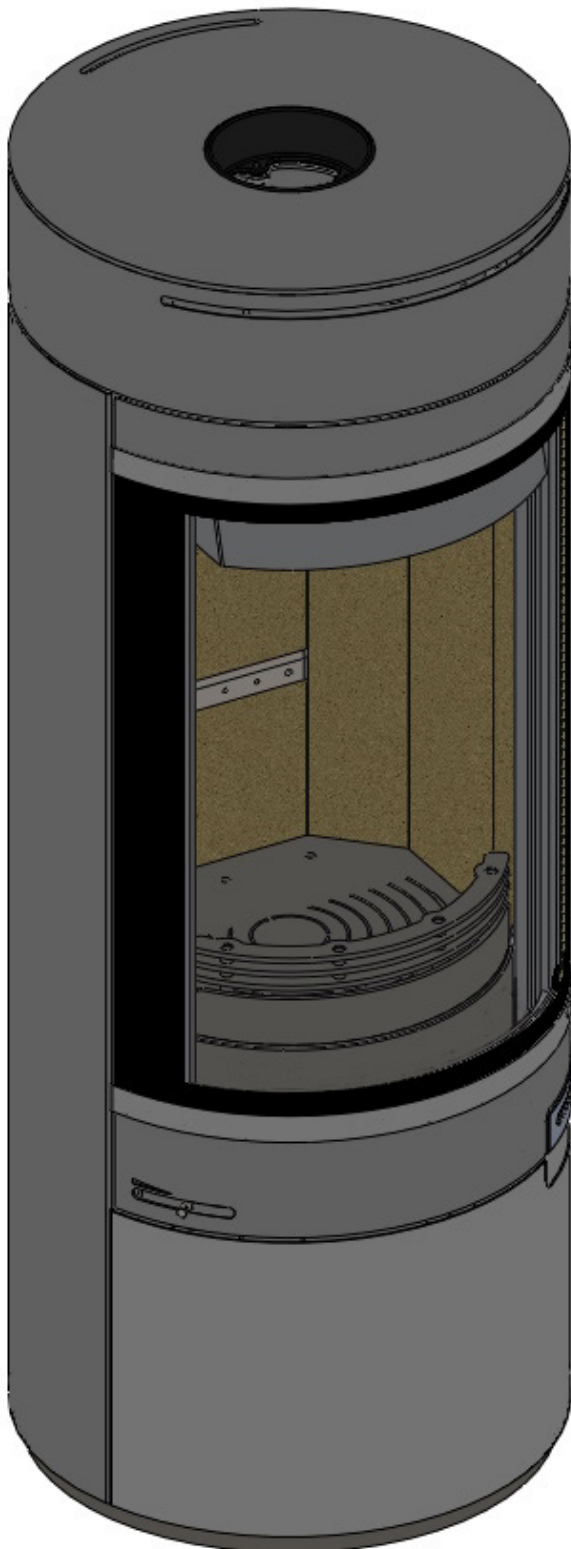

5.9 Lighting the Appliance

IMPORTANT NOTES

Before lighting the stove check with the installer that the installation work and commissioning checks described previously have been carried out correctly and that the chimney has been swept clean, is sound and free from any obstructions.

As part of the stove's commissioning and handover, the installer should have shown you how to operate the stove correctly.

Hunter Stoves recommends the top down lighting method for a cleaner and more convenient start.

1. Ensure the air control is in the fully open position.
2. In the base of the stove, place 2 larger split and dry logs. Ensure a gap is left between the logs as this allows air movement to help the fire breathe when lit.
3. Place 2 smaller logs on top at 90° to the bottom logs.
4. Layer approximately six to eight pieces of kindling (finely chopped wood) on top of the logs in a crisscross pattern.
5. Place 1 or 2 eco fire lighters on top of the kindling in the centre.
6. Finally, place 2 to 4 thin pieces of kindling on top of the eco fire lighters.
7. Close the door as soon as flames appear.
8. A small amount of soot may appear on the glass during the lighting. This is perfectly normal and will go after a period of time.
9. Extra logs should not be added until the logs have burnt down into a bed of glowing embers.

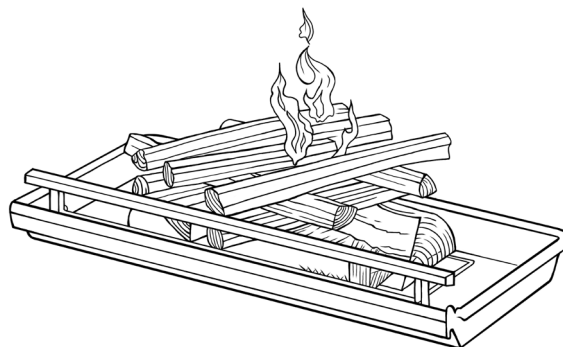
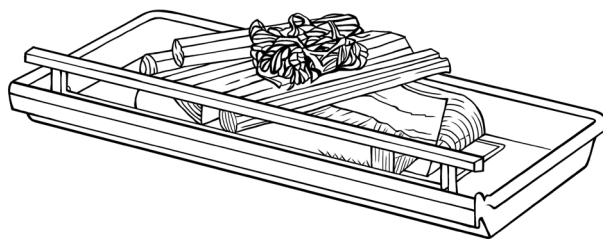

Wood Weights

For a 5kW stove, we recommend approximately 1.1-1.4kg of wood.

This will give you 3/4 to 1 hour burn.

Please note the the exact amount of wood to use is dependent on the species of wood, the moisture content, and the desired burn

Kindling:

Length - 15cm to 20cm

Diameter - 1cm to 3cm

Approximately 8-12 finely chopped pieces

Kindling is required to bridge the gap between firelighters and logs, creating the initial heat required for clean combustion.

A lack of kindling may cause the fire to smoulder or potentially go out.



5.10 Running the Appliance

1. Only refuel when the fire has died down to embers. Ensure that the wood you are using has a moisture content of less than 20% (we recommend 12-15% to ensure an efficient burn).
2. When refuelling open all the air controls fully and the damper (if fitted).
3. Open the door slowly by releasing the handle and allowing to stay like this for 5 to 10 seconds. Opening the door too fast will cause smoke to be drawn into the room as the firebox has not had time for the pressure to equalise. The smoke will then take the easiest route which is out through the opening.
4. Fully open the door slowly and break apart the remaining char, distributing it across the base of the firebox.
5. Carefully place the logs in. It is recommended you use 2 pieces of wood, placed parallel with each other and the stove glass. Please do not load the wood any higher than the Rear Turbo Bar (~160mm).
6. Close the door. (All our stoves are tested as closed door appliances and should be used as such.)
7. Keep the air control in the fully open position until the logs catch fire.
8. After a few minutes once the flames are fully established, slowly close the air control for a more efficient burn.

Guide to Wood

Hardwood is a denser fuel than softwood and provides a higher heat content. Softwood produces 50% less heat content than hardwood. Softwoods are more prone to spitting and popping as they have pockets of moisture and sap contained within them (this can be reduced by seasoning and drying correctly).

Woods suitable for closed appliances - Ash, Beech, Birch, Blackthorn, Elm, Eucalyptus, Hawthorn, Hazel, Hornbeam, Maple, Oak, Rowan, Sycamore, Wild Cherry, Willow, Alder, Apple, Pear and Holly. (Oak, Beech and Birch burn at the highest rate when seasoned correctly).

These woods are also suitable but can crackle and spit -

Cedar, Douglas Fir, Horse Chestnut, Larch, Plane, Sweet Chestnut and Willow.

IMPORTANT!

Ensure the wood has a moisture content of less than 20% (we advise 12-15% for a more efficient burn) to allow the fuel to catch quickly. If the fuel has a higher moisture content then you are burning the water off and this will reduce the heat output and take longer to burn correctly. This can also cause a build up of soot and tar which could lead to a chimney fire. It will also cause the glass of the stove to blacken.

Refuelling must be carried out with a sufficient quantity of glowing embers and ash, so that the new fuel charge can ignite quickly. If there are too few embers, add some kindling to prevent excessive smoke. After refuelling leave the air control fully open for one minute before reducing to the desired setting.

FUEL OVERLOADING

The maximum amount of fuel specified in this manual should not be exceeded, overloading can cause excess smoke.

WARNING!

Burning wet or unseasoned wood will create excess smoke emissions, tar deposits in the stove and chimney, and will not produce a satisfactory heat output.

DO NOT BURN BITUMINOUS COAL, PETRO-COKE, OTHER PETROLEUM BASED FUELS OR TREATED WOOD SUCH AS PALLETS. THIS WILL INVALIDATE THE PRODUCT WARRANTY. HOUSEHOLD WASTE MUST NOT BE BURNT ON THIS APPLIANCE.

OVER-FIRING

Using an excess amount of wood and/or leaving the air intake open can cause the stove to over-fire. This can cause damage to both the stove and the surrounding walls.

INSTALLATION & SERVICING

6.1 Overview of a Typical Top Flue Installation

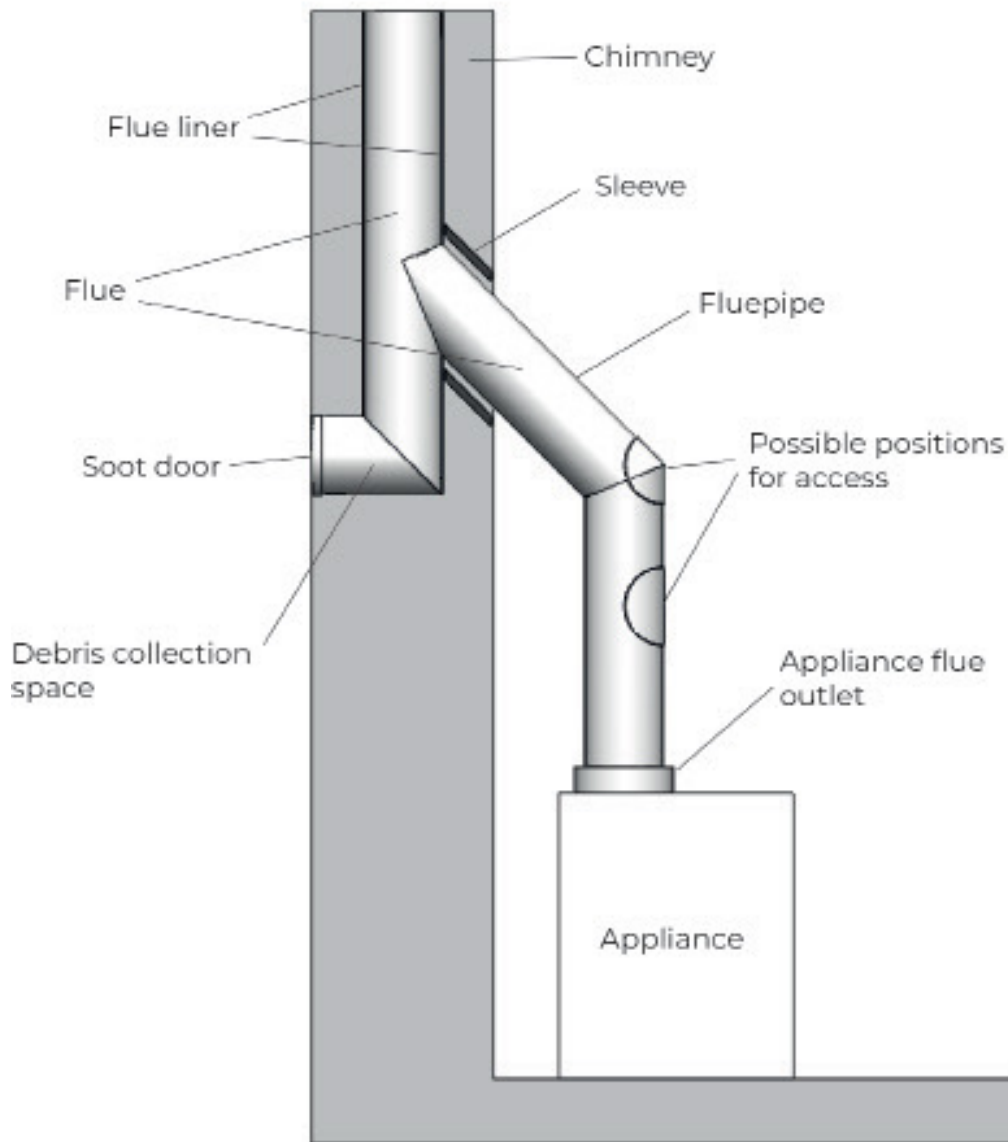

6.2 Commissioning

- Once the stove has been installed and the flue connected, replace all the internal components of the stove which were removed for installation.
- Check the seal between the door, flue and joints are sound.
- Check the air controls are working correctly and are smooth to operate.
- Conduct a draught test.
- Check the CO monitor is working correctly.
- Once the draught test is satisfactory, the appliance is deemed safe for use and the stove can be lit for the first time.
- Light the appliance as described in these instructions.
- Ensure the temperature is increased slowly to allow the fire cement and paint to cure.
- Check that no products of combustion are entering the room (e.g. smoke).
- If everything is operating correctly explain to the user how to operate the appliance, the safety measures they should take and how to maintain the appliance.
- Ensure that these instructions are given to the user.

6.3 Servicing Checklist

Hunter Stoves Group recommend that this appliance has a major service annually, preferably prior to the start of the heating season, thus avoiding any delay in receiving replacement components, should you need them. Hunter Stoves recommend that you contact the installation engineer for advice.

Before commencing any work ensure the appliance and area is safe and accessible to conduct the service.

- Ensure the appliance is cool.
- Ensure any ash remaining in the appliance has had time to cool to room temperature, then remove it before servicing.
- Remove all internal components and check for damage.
- Check the flue and if necessary sweep.
- Vacuum the inside of the stove and clean any soot deposits that have formed on the steel surfaces using a dry cloth.
- Check the appliance for any damage.
- Check the condition of the paint work. Touch up paint is available if required.
- Fit new door rope, if required.
- Clean the glass.
- Replace internal components.
- Check the appliance is operating correctly and safely, following commissioning instructions.

6.4 Servicing Notes

Catalyst Servicing

The catalyst is self-cleaning in normal operational mode. However in some situations such as burning poorly seasoned or smoky wood, or if there is a poor chimney draught or the fire is burnt in a slow mode for long periods, then soot may accumulate on the surfaces of the catalyst.

The fire should be burnt at a high heat on a regular basis to help burn off any soot that may start to accumulate

To clean the catalyst, first remove it from the stove then simply dust off any soot with a dry paint brush, gently blow through it with an air line or pump, being careful not to inhale any dust, or gently vacuum over the faces, being careful not to brush or touch the face with hard objects which could damage the delicate foil substrate.

A correctly functioning catalyst will show a light covering in dry grey ash, which is easily removed as above. If it is heavily coated in black soot, with evidence of blocked cells, then the catalyst should be brushed off, and then washed in cold water. Do not use any detergents which will damage the coating.

It is recommended to inspect and clean the catalyst once per month during the heating season, or whenever there is abnormal blackening of the stove door glass, or a poor draw from the fire.

Do not burn any other products than wood, ie coal, as the sulphur will damage the coating and may render it ineffective.

Do not use any other chemical containing products, such as flue cleaning logs as these too will damage the coating.

If a catalyst is showing signs of blocking or damage it should be replaced, and returned to Hunter Stoves Limited for inspection.

Periods Of Prolonged Non-Use

If the stove is to be left unused for a prolonged period, then it should be given a thorough clean to remove ash and unburned fuel residues. To enable a good flow of air through the appliance to reduce condensation and subsequent damage, leave the air controls fully open. If the appliance has been unused for a long period, such as during the spring and summer months, a competent person should check the chimney for potential obstructions before lighting the stove e.g. Have the chimney swept before the start of the heating season.

6.4 Servicing Notes

* All spares can be obtained through your original retailer or via the spares section of the Hunter Stoves website www.hunterstoves.co.uk.

Stove Body

You can wipe the stove with a dry cloth. Repair any light damage with Hunter Stoves' stove paint available through our website.

Fire Bricks

With normal use, these can last for many years. It is possible however for the bricks to crack if logs are continually jammed against them or if they are frequently struck with a poker. Check periodically for seriously cracked/crumbling bricks, which can be replaced with new bricks.

Rope

Check the rope around the door. If the rope is becoming worn and/or compressed or is in a poor condition, a replacement rope kit should be ordered.

Chimney and Flue Ways

It is important that the chimney, flue ways and any connecting flue pipe are swept regularly. This should only be carried out by an experienced chimney sweep with a trusted trade rating.

This means at least twice a year for wood. The brick and steel baffles, together with the catalyst will need to be removed from the stove in order to sweep the chimney. If it is not possible to sweep all parts of the chimney through the appliance, ensure there is adequate access to cleaning doors. If the stove is fitted in place of an open fire, then the chimney should be swept one month after installation to clear any soot falls which may have occurred due to the difference in combustion between the stove and the open fire.

WARNING NOTE

Properly installed and operated, this appliance will not emit fumes. Occasional fumes from de-ashing and refuelling may occur. Persistent fume emission must not be tolerated.

This appliance should not be operated with the door open.

If fume emission persists, then the following immediate actions should be taken:

- Open doors and windows to ventilate the room
- Let the fire go out or safely remove and dispose of fuel from the appliance
 - Check for flue/chimney blockages and clean if required
- Do not attempt to re-light the fire until the cause of the fume emission has been identified and corrected.

If necessary, seek expert advice.

6.5 General Notes

Fireguards

Always use a fireguard in the presence of children, the elderly or the infirm. The fireguard should be manufactured in accordance with BS8423 – Fireguards for use with solid fuel appliances.

Extractor Fan

Fitting a stove in a room which also contains an extractor fan and/or cooker hood should be avoided where possible. If this is unavoidable, the suitability of the space for fitting this appliance must be decided at the discretion of a qualified installer, and a flue draught interference test must be performed.

Ventilation

It is essential that the stove has an adequate air supply for combustion and ventilation. Requirements can be found by checking Building Regulations Approved Document J. Do not obstruct the ventilation required for the safe use of this appliance.

In The Event Of A Chimney Fire

- Raise the alarm
- Call the Fire Brigade
- Close appliance air controls
- Move furniture, ornaments etc. away
- Place a fireguard in front of stove
- Check the chimney breast for signs of excessive heat.

If the wall is becoming excessively hot, move furniture away.

Ensure the Fire Brigade can gain access to your roof space in order to check for fire spread.

6.6 Glass Replacement

To replace the glass, unscrew the M5 nuts that hold the upper glass retainer in place and then remove. Ensure that you hold the glass in place.

Then slacken the M5 nuts on the lower retainer and lift the glass away from the door.

To replace a glass panel please ensure you purchase new self adhesive rope at the same time. Do not overtighten the M5 nuts when replacing the retaining panels.

Printed glass should not be cleaned using cleaners high in alkaline or acidic content. Clean the glass panel when cool with a propriety glass cleaner by applying the cleaner to a cloth. Do not apply directly to the glass as this could cause run of which could soak into the rope seals around the edge of the glass.

Highly abrasive substances should be avoided as these can scratch the glass and make subsequent cleaning more difficult. Wet logs on heated glass, a badly aimed poker or heavy slamming of the doors could crack the glass panels, **the glass will not fracture from heat alone.**

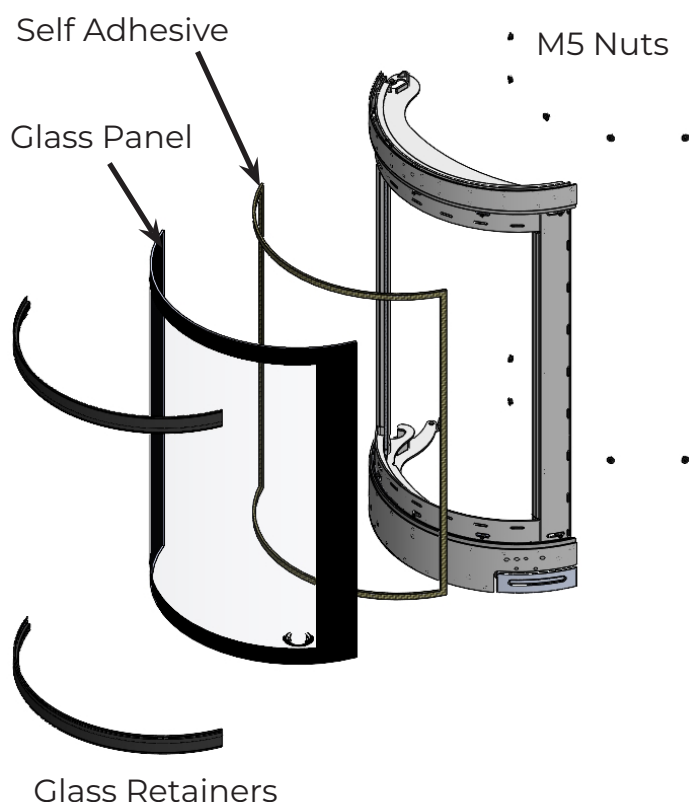

6.7 Rope Seal Replacement

The door seal rope sits in a deep channel around the periphery of the door. It is not glued into position so it can easily be removed and replaced.

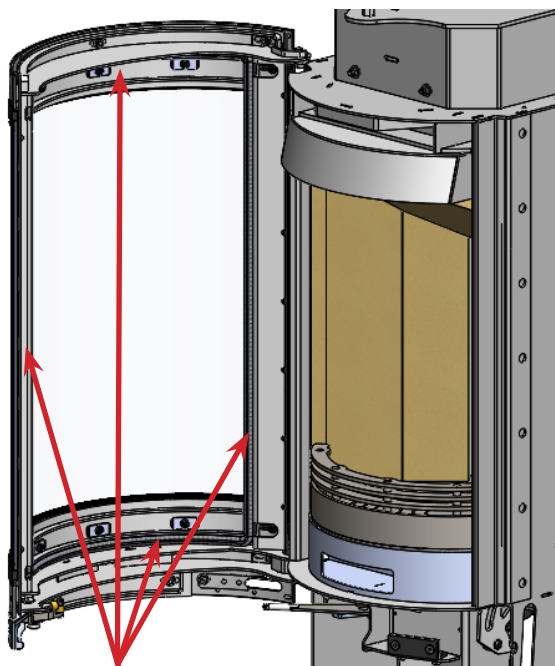

Door Rope Seal

6.8 Handle Adjustment

If the handle has excess movement, when the door is closed, you can adjust this by slackening the M6 nuts shown and moving the wear strip forward to touch the roller and then re-tighten.

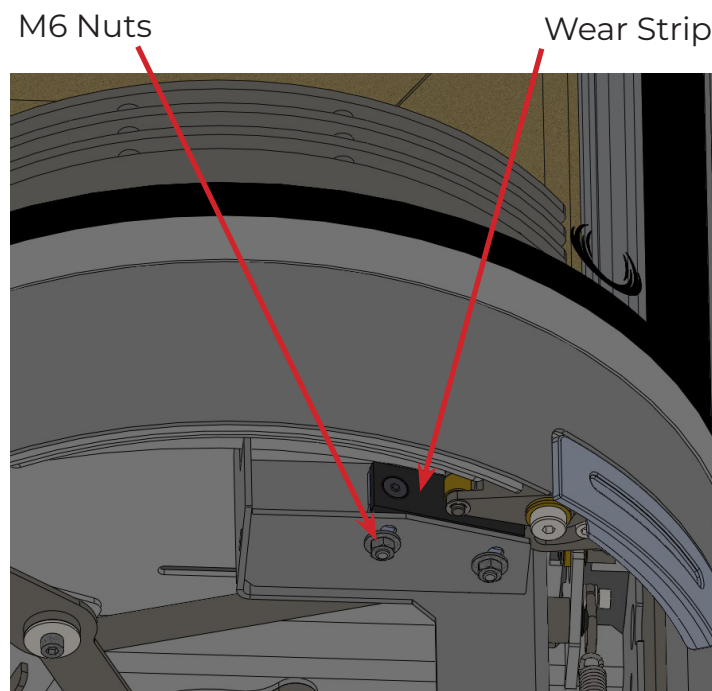

TROUBLESHOOTING

Smoke

This can happen for a variety of reasons e.g cold air trapped in chimney/flue. As cold air is denser, this causes smoke to be forced back down the chimney. We recommend trying to heat the chimney before lighting for example, placing a firelighter on top of the kindling.

Ensure wood has a moisture content of less than 20% as this can cause excess smoke. Also check the type of wood as softwood produces a lot more smoke. Operation with the air control or appliance dampers open can cause excess smoke. The appliance must not be operated with air controls, appliance dampers or door left open except as directed in the instructions.

Operation with the door open can cause excess smoke. The appliance must not be operated with the appliance door left open except as directed in the instructions.

Glass

If your glass is blackening this can be due to incorrect use of the air control (see instructions).

Alternatively, poor quality fuel which has a high moisture content can also be a cause.

When the glass has a white shadow (or crazing) on the inside then this can be caused due to over-firing, too much primary air or a vacuum in the room.

Operation Of Fire

There are several potential reasons for issues with your stove. One common cause could be an improper flue draft, either too low or too high, in which case you should consult your installer. Ensure proper use of the air controls by referring to the stove's instructions. The quality and moisture content of the fuel are also important factors. Additionally, check that the chimney is not blocked, and ensure that nearby buildings or trees are not affecting airflow around it.

Weather Conditions

Varying weather can have an impact on the way the stove burns, especially the wind. An anti-down draught cowl might need to be fitted (speak to a specialist) or a flue damper may also be of help.

Mist and fog may also have an impact on the chimney draught and you will need to change the settings you are using on the stove.

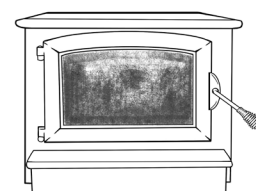

Appliance Body

Paint Curing

The stove paint curing process takes place at room temperature and the surface coating is virtually free from fumes and odours. When being put into operation for the first time we would recommend that windows and doors are opened for a short time to provide ventilation.

If the surface of the appliance turns grey or the paint starts to flake or peel then this is caused by over-firing.

Noise

When the appliance body heats up and cools down it may make some clicking noises. This is due to the large temperature differences and is not a problem with the appliance.

Fire Goes Out After A Short Time

- Check the flue draught of the stove is not too strong or too low.
- Is the air vent blocked?
- Check use of air controls (please refer to these instructions).
- Ensure that the amount of kindling used is enough to light the added fuel.
- Try heating the flue/chimney up first to ensure air pressure is not allowing the flue to operate correctly.



PACKAGING

All our packaging both for our stoves and spares is recyclable. For information detailing where it can be disposed check with your local council.

WARRANTY

2 Year Standard Warranty

Any appliance bought through the showroom of an authorised Hunter Stoves Group dealership will automatically be covered by our standard 2-year conditional guarantee.

However, this standard 2-year warranty can be extended to a 5-year or 10-year conditional warranty dependent on the model type (5 years - Boiler model and Gas models, 10 year - Room heater).

To qualify for this extended warranty option, you need to:

1. Register your purchase online at <https://www.hunterstoves.co.uk/product-registration>
2. Retain your proof of purchase.

Warranty Conditions

For the Standard 2 year or extended 5/10-year warranty to be valid and to remain in force throughout the warranty period the following must have been carried out:

1. The appliance must have been installed by an appropriately qualified engineer (from the Competent Person Scheme/Gas Safe) in accordance with the manufacturer's instructions and in compliance of any relevant national or local building regulations. Please visit the following links for details on the Competent Person Scheme: <https://www.gov.uk/guidance/competent-person-scheme-current-schemes-and-how-schemes-are-authorized> and Gas Safe register: <https://www.gassaferegister.co.uk/>
2. The appliance will need to be registered within two months of purchase and the commissioning and installation documentation completed (these need to be kept by the end user).
3. The appliance must be serviced within 12 months of the installation date for the second year of the standard warranty to be valid, and within every 12-month anniversary thereafter to maintain the validity and coverage of any extended warranty. For this purpose, the installation and user instructions, supplied with the appliance, makes a provision for receipts and annual services to be recorded. This is needed in the event of a claim during the warranty period.
4. Only genuine Hunter Stoves spare parts or consumables can be used in the servicing and maintenance of the appliance during any standard or extended warranty period. These can be sourced from your authorised supplier directly or through our website spares portal. www.hunterstoves.co.uk/spares.
5. Any problems or issues giving rise to any claim under the standard or extended warranty must be submitted to the authorised Hunter Stoves Group retailer from whom you originally purchased the appliance. Hunter Stoves Group will then offer appropriate support and help through your original authorised supplier to solve any issues.
6. The standard or extended warranty option is not transferable. It is solely for the benefit of the original purchaser of the appliance. For this purpose, please retain the proof of purchase.

Warranty Exclusions

For Solid Fuel Stoves:

- Glass and rope/ceramic seals
- Fire bricks
- Baffles/Throat Plates
- Log retainers, grate supports and catch bars
- Grate parts
- Ashpans
- Clip-in Boilers

For Gas Stoves:

- Gas pilot assemblies
- Thermocouples and Oxy pilots
- Ceramic log and coal 'fuel-effects'
- Batteries

Paint and Surface Coverings

The paint or surface covering of the appliance will be covered (for 1 year after installation) provided the warranty conditions are met. However, damage due to the following events will not be covered:

1. Damage to the paint surface caused by the appliance being stored in a damp and cold environment is not covered under warranty. Please be aware that any moisture within the room where the stove is installed e.g. through clothes drying, can be a cause of paint issues.
2. In the course of the initial firings of the appliance the paint or enamel surface may change colour. This is normal and as such is therefore not covered under warranty.
3. Damaged caused by over firing, resulting in cracking, bubbling or discolouration to the paint or enameled surface finish is not covered under warranty.

Warranty Limitations

1. Damage to the appliance due to specific local conditions caused by draft or chimney defects.
2. Damage resulting from installation and use where installation is not in accordance with the manufacturer's instructions or local building and/or safety regulations.
3. Damage or premature wear caused by burning inappropriate fuels such as Bituminous coal, "Petro-Coke" or any other Petroleum based coals. Please visit the HETAS website, www.hetas.co.uk, for a full list of approved fuels which are covered by the warranty. Fuels outside of this list are not covered by the warranty.
4. Damage caused by burning material with high creosote content or any other painted/treated timber.
5. Consequential loss to associated non-Hunter Stoves Group products is not covered under the warranty.
6. Consequential loss relating to decorations, soft furnishings or other household assets is not covered under the warranty.
7. Cost associated with the removal and re-installation of an appliance subject to a warranty claim.

Hunter Stoves Group total liability will only extend to the total purchase price paid for the goods in any warranty claim. Hunter Stoves Group reserve the right to replace, repair or refund to value of goods purchased.

ANY HUNTER STOVES GROUP PRODUCT PURCHASED VIA AN INTERNET SUPPLIER, OR THROUGH AN UNAUTHORISED STOCKIST WILL ONLY BE SUPPORTED BY THE STATUTORY, 12 MONTH GUARANTEE AND WILL NOT QUALIFY FOR ANY EXTENDED 5 OR 10 YEAR WARRANTY.

The Hunter Stoves Group extended warranty option does not affect your statutory rights.

This revised standard or extended 5 or 10-year warranty option comes into effect on 1st September 2015 and will apply to all appliances sold from that date.

This standard/extended warranty applies to purchases of Hunter Stoves within the United Kingdom and the Republic of Ireland. Purchases in all other countries are subject to the warranty conditions specified by the distributor in those markets.

If any further help is needed then please refer to the Help section on our website - <https://www.hunterstoves.co.uk/help> or contact your dealer.



SMOKE CONTROL AREA EXEMPT

The Clean Air Act 1993 and Smoke Control Areas

Under the Clean Air Act local authorities may declare the whole or part of the district of the authority to be a smoke control area. It is an offence to emit smoke from a chimney of a building, from a furnace or from any fixed boiler if located in a designated smoke control area. It is also an offence to acquire an “unauthorised fuel” for use within a smoke control area unless it is used in an “exempt” appliance (“exempted” from the controls which generally apply in the smoke control area).

In England appliances are exempted by publication on a list by the Secretary of State in accordance with changes made to sections 20 and 21 of the Clean Air Act 1993 by section 15 of the Deregulation Act 2015. In Scotland appliances are exempted by publication on a list by Scottish Ministers under section 50 of the Regulatory Reform (Scotland) Act 2014. Similarly, In Northern Ireland appliances are exempted by publication on a list by the Department of Agriculture, Environment and Rural Affairs under Section 16 of the Environmental Better regulation Act (Northern Ireland) 2016. In Wales appliances are exempted by regulations made by Welsh Ministers.

Further information on the requirements of the Clean Air Act can be found here:
<https://www.gov.uk/smoke-control-area-rules>

Your local authority is responsible for implementing the Clean Air Act 1993 including designation and supervision of smoke control areas and you can contact them for details of Clean Air Act requirements.

Each stove must be fitted with a permanent stop provided by the Hunter Stoves to prevent full closure of the air controls. In a smoke control area, the air control stop must be fitted. If this is removed, then the stove will no longer be exempt and therefore no longer suitable for burning unauthorised fuels in a smoke control area.

The Halo Radial has been recommended as suitable for use in smoke control areas when burning wood logs.

The Halo Radial must be fitted with a permanent stop to prevent closure of the secondary air control beyond 41% open.

Refuelling On To A Low Firebed

If there is insufficient burning material in the firebed to light a new fuel charge, excessive smoke emission can occur. Refuelling must be carried out onto a sufficient quantity of glowing embers and ash that the new fuel charge will ignite in a reasonable period. If there are too few embers in the fire bed, add suitable kindling to prevent excessive smoke.

Fuel Overloading

The maximum amount of fuel specified in this manual should not be exceeded, overloading can cause excess smoke.

Operation With Door Left Open

Operation with the door open can cause excess smoke. The appliance must not be operated with the appliance door left open except as directed in the instructions.

Dampers Left Open

Operation with the air controls or appliance dampers open can cause excess smoke. The appliance must not be operated with air controls, appliance dampers or door left open except as directed in the instructions.

SERVICE RECORDS

1st SERVICE Date of service..... Date of next service..... HETAS Number..... Signature.....	2nd SERVICE Date of service..... Date of next service..... HETAS Number..... Signature.....
3rd SERVICE Date of service..... Date of next service..... HETAS Number..... Signature.....	4th SERVICE Date of service..... Date of next service..... HETAS Number..... Signature.....
5th SERVICE Date of service..... Date of next service..... HETAS Number..... Signature.....	6th SERVICE Date of service..... Date of next service..... HETAS Number..... Signature.....
7th SERVICE Date of service..... Date of next service..... HETAS Number..... Signature.....	8th SERVICE Date of service..... Date of next service..... HETAS Number..... Signature.....
9th SERVICE Date of service..... Date of next service..... HETAS Number..... Signature.....	10th SERVICE Date of service..... Date of next service..... HETAS Number..... Signature.....
11th SERVICE Date of service..... Date of next service..... HETAS Number..... Signature.....	12th SERVICE Date of service..... Date of next service..... HETAS Number..... Signature.....



hunterstoves
GROUP

Hunter Stoves Ltd, 8 Emperor Way, Exeter Business Park, Exeter, Devon, EX1 3QS

www.hunterstoves.co.uk Email: info@hunterstoves.co.uk



hunterstoves

G R O U P

8 EMPEROR WAY EXETER DEVON EX1 3QS
INFO@HUNTERSTOVES.CO.UK WWW.HUNTERSTOVES.CO.UK

Hunter Stoves reserve the right to change dimensions and procedures described in these instructions at anytime without special notice.

Registered address: Hunter Stoves Ltd., Trevilla Park, Slaughterbridge, Camelford, Cornwall, UK, PL32 9TT